

# Ki-Kern

Heavy duty plastic plates  
for building and industry

## Technical information

- Simple to assemble
- Low-maintenance
- Very durable
- Colourfast
- Environmentally-friendly
- Retains its shape
- Impact and shock resistant
- Extremely weather-proof
- High quality in accordance with ISO standards
- 10 year guarantee
- Conforms with BRL 4101
- KOMO certification with product certificate (GB-003)



**KI-KERN®**

Version 09/2008

Copyright

Nothing from this publication may be duplicated without prior written permission from Fetim Professional. Changes to specifications and printing errors reserved.



## **Index**

1.0	Ki-Kern introduction	4
2.0	Technical specifications	6
3.0	Tooling	11
4.0	Processing	12
5.0	Drawing sheets	17
6.0	Cleaning Ki-Kern	31
7.0	Resistance	32

### **Importer Fetim Professional**

PO Box 770, 1000 AT AMSTERDAM

Tel. +31 (0)20-580 52 85 Fax +31 (0)20-580 53 65

E-mail: [professional@fetim.nl](mailto:professional@fetim.nl)

Internet: [www.FrontsAndFronts.nl](http://www.FrontsAndFronts.nl)

[www.fetimprofessional.nl](http://www.fetimprofessional.nl)

## **1.0 Introduction**

We would like to thank you for your interest in Ki-Kern wall cladding. We are convinced that choosing Ki-Kern will lead to the required result. An essential factor to ensure this, is to follow this technical documentation. The documentation will clearly explain how to best install Ki-Kern. The processing instructions have been verified by Intron Certificatie B.V. (certification body recognised by the Dutch Accreditation Council) and have been included in the KOMO certificate that includes a product certificate.

### **Description:**

Ki-Kern boarding base is formed by thermoset synthetic material. The boards are homogeneously reinforced with cellulose fibre and provided with an integrated decorative pigment (colour) layer. The core material consists of impregnated cellulose layers. The top layers consist of pigmented cellulose layers saturated in melamine resins. Independent test reports and practical experience have now proven that Ki-Kern more than meets the set standards for synthetic material boards. The material is odour free and resistant against moulds, bacteria and living organisms. Ki-Kern is mainly applied in ventilated wall systems. This creates an excellent insulation value and a contribution is made to a healthier indoor climate. It ensures that the wall is ventilated on warm days and, thus, the heat is removed.

### **Other available documentation:**

- Ki-Kern brochure
- Ki-Kern colour folder
- KOMO certificate that includes a product certificate (GB-003)
- Colour guides and colour chips
- Internet: [www.FrontsAndFronts.nl](http://www.FrontsAndFronts.nl)  
[www.fetimprofessional.nl](http://www.fetimprofessional.nl)

## **2.0 Technical Specifications**

### **2.1 Assessment**

Ki-Kern wall cladding has been assessed in accordance with:

- BRL 4101 part 1 "Wall cladding systems with panels; general criteria"
- BRL 4101 part 4 "Additional requirements for decorative boarding based on thermoset resins"
- Applicable NEN standards
- Dutch Building Decree
- Dutch Building Materials Decree

Ki-Kern Wall cladding is suitable for application as decorative and moisture-resistant wall cladding for exterior divisions with regard to:

- Fascias
- Roof and gutter edges
- Ceilings
- Dormers
- Balcony fencing and partitions
- Front and frame filling
- Changing booths
- Toilet blocks
- Cool rooms
- Street furniture

#### **Application conditions:**

1. The product must be installed in accordance with the instructions as specified in this technical documentation.
2. The wall behind must be sufficiently strong and stiff and must be linked to the foundations in such a way that the stability of the building structure is guaranteed and that the net loads on this can be transferred to the foundations.

### **2.2 General Algemeen**

Ki-Kern is a flat board based on thermoset resins that has been homogeneously reinforced with fibres and produced under high pressure and temperature. The boards are provided with an integrated decorative surface based on pigmented resins. Ki-Kern panels can be supplied in various colours as standard.

Ki-Kern is supplied as a standard type (STD) that meets class C in accordance with EN 13501-1. A fire-retardant type can also be supplied upon request (FR) that meets class B in accordance with EN 13501-1.

#### **Dimensions and size tolerances**

Ki-Kern panels can be supplied in the following sizes:

- 2440 x 1295 mm
- 2500 x 1295 mm
- 3050 x 1295 mm

Other dimensions are possible upon request

The thickness of the panels are 6, 8 of 10 mm

### 2.3 Size tolerances

Measurements	Tolerances	Norm
Thickness	± 0,35 mm for 6 mm	EN 438
	± 0,40 mm for 8 mm	
	± 0,45 mm for 10 mm	
Length	- 0/+ 10 mm	
Width	- 0/+ 10 mm	
Squareness deviation	≤ 1,5 mm/m	
Rectilinearity	≤ 1,5 mm/m	
Flatness	≤ 5 mm/m	

### 2.4 Material properties

Properties	Value	Entity	Norm
Elasticity modulus	≥ 9.000	N/mm <sup>2</sup>	ISO 178
Bending strength	≥ 80	N/mm <sup>2</sup>	ISO 178
Voluminous mass	≥ 1350	Kg/m <sup>3</sup>	ISO 1183
Resistance against moisture: - Mass increase - Assessment	≤ 4 4	% class	EN 438-2 (15)
Tensile strength/surface	≥ 60	N/mm <sup>2</sup>	EN ISO 527-2
Impact resistance: - Falling height	≥ 2000	mm	EN 438-2 (21)
Dimensional stability at an increased temperature	≤ 5.5	mm/m	EN 438-2 (17)
UV-resistance - Colour difference - Cracking - Blistering - Gloss difference	3 or better 4 – 5 None ≤ 50	Grey scale (ISO 105 – A02) class %	EN 438-2 / BRL 4101-4
Combustibility	C-s2,d0 B-s2,d0	class (STD) (FR)	EN13501-1

### 2.5 BUILDING STRUCTURE BEHIND

The building structure behind must meet a number of criteria with regard to the designated use of the wall cladding system.

These criteria relate to the following:

- General strength of the building structure
- Fire safety
- Protection against harmful or irritating influences
- Thermal insulation

### **2.5.1 General strength of the building structure**

The structure behind must, as a part of the wall structure, meet the performance criteria for the general strength of the building structure as referred to in table 2.1 of the Dutch Building Decree.

The anchoring of the wall cladding system to the building structure behind must be such that no utmost limit state or usability limit state is exceeded during the reference period.

### **2.5.2 Fire safety**

The structure behind must meet the performance criteria related to the resistance for the containment of the spread of fire as referred to in table 2.103 of the Dutch Building Decree. This means that the resistance against the spread of fire of the structure behind tested in accordance with NEN 6069 must amount to 20, 30 or 60 minutes (depending on the use that will be made of the structure) from indoors to outdoors and vice versa.

### **2.5.3 Limitation with regard to fire risks occurring**

If provisions are added at the location or near to a hearth and/or near to a provision for the discharge of smoke in such a way that Articles 2.82 and 2.84 of the Dutch Building Decree are met, the wall cladding will meet the performance criteria as referred to in table 2.81 of the Dutch Building Decree.

### **2.5.4 Limitation of the development of fire**

The side of the wall cladding system with Ki-Kern that faces outwards meets the performance criteria with regard to the limitation of the development of fire as referred to in table 2.91 of the Dutch Building Decree. Ki-Kern type FR may have to be applied or Ki-Kern (STD) may be sufficient depending on the designated use as specified in table 2.91 of the Dutch Building Decree.

### **2.5.5 Limitation of the spread of fire**

The resistance against the spread of fire is derived from the building structure behind.

If this condition is met, the wall structure will meet (see section 5.0 fig. 1) the performance criteria with regard to the containment of the spread of fire as referred to in table 2.103 of the Dutch Building Decree.

### **2.5.6 Limitation of the development of smoke**

Ki-Kern and Ki-Kern FR panels meet the performance criteria with regard to the limitation of the development of smoke as referred to in table 2.125 of the Dutch Building Decree. The performance criterion will rarely apply because it does not refer to buildings on a side that is adjacent to the external air.

## 2.6 Health

### 2.6.1 Protection against noise from outside

The performance is derived from the structure behind. If this condition is met, the wall structure will meet (see section 5.0 fig. 17) the performance criteria with regard to the protection against noise as referred to in table 3.1 of the Dutch Building Decree.

### 2.6.2 Prevention of moisture penetration from outside

The performance with regard to the prevention of moisture penetration from outside as referred to in table 3.22 of the Dutch Building Decree is derived from the structure behind (see section 5.0 figures 17 and 18). A maximum verification pressure applies for the provided application example in accordance with table 2 of NEN 2778 (incl. the amendment to NEN 778:1991/A3:2004). Additional conditions are implementing an air-tight installation for the internal wall of the ventilated wall structure and having a continuous cavity width of at least 20 mm. Under these assumptions, the wall structure will meet the performance criteria with regard to the prevention of moisture penetration from outside as referred to in table 3.22 of the Dutch Building Decree. If open joints are used, the condition will also apply that the structure behind and the insulation material must be moisture-resistant. A water-retaining, moisture-pervious membrane can also be applied.

### 2.6.3 Prevention of moisture penetration from inside

The wall structure with Ki-Kern panels meets the performance criterion with regard to the prevention of moisture penetration from inside as referred to in table 3.26 of the Dutch Building Decree. This performance is derived from the structure behind. (See section 5.0 figures 17 and 18) For the application example provided, the following applies in accordance with NEN 2778 (incl. the amendment to NEN 2778:1991/A3:2004): for structures with a residential designated use  $F_{ri} > 0.65$  and for structures without a residential designated use  $F_{ri} > 0.50$ .

### 2.6.4 Limitation of the application of hazardous materials

Ki-Kern panels meet the performance criterion with regard to the limitation of the application of materials that may release toxic or irritating substances as referred to in table 3.106 of the Dutch Building Decree.

### 2.6.5 Protection against rats and mice

The wall structure with Ki-Kern panels meets the performance criteria with regard to the protection against rats and mice as referred to in table 3.114 of the Dutch Building Decree. The condition is that cross profiles must be used between the Ki-Kern panels (see figure 3 on page 12) with regard to wall cladding systems with open joints that are wider than 10 mm.

## 2.7 Energy efficiency

### 2.7.1 Thermal insulation

The wall structure with Ki-Kern panels meets the performance criteria with regard to the thermal insulation as referred to in table 5.1 of the Dutch Building Decree. This performance is derived from the structure behind (see section 5.0 figures 17 and 18). For the application example provided and the structures behind:  $R_c = > 2.5 \text{ m}^2\cdot\text{K}/\text{W}$ .

### 2.7.2 Air permeability

The wall structure with Ki-Kern panels meets the performance criterion with regard to air permeability as referred to in table 5.8 of the Dutch Building Decree. This performance is derived from the structure behind.

## **2.8 Aspects related to the composition of the panels**

### **2.8.1 Ozone layer attacking substances**

The Ki-Kern wall cladding panels meet the Dutch Decree related to substances that may negatively affect the ozone layer.

### **2.8.2 Cadmium**

The Ki-Kern wall cladding panels meet the Dutch Cadmium Decree.

### **2.8.3 Heavy metals**

The Ki-Kern wall cladding panels do not contain heavy metals.

### **2.8.4 Asbestos**

The Ki-Kern wall cladding panels meet the Dutch Working Conditions Asbestos Decree and the Dutch Commodities Act Asbestos Decree.

## 3.0 Tooling

### 3.1 Sawing using a circular saw

Ki-Kern should be sawn on a permanent sawing table provided with a circular saw with a (negatively sharpened) trapezium teeth. This saw plate must be suitable for sawing hardened metal. The following saw specifications are recommended:

Diameter of the saw blade	mm	300
Machine speed	rpm	≥ 4000
Thickness of the saw blade	mm	3.0 – 4.05
Number of saw teeth	-	≥ 96
Distance between the teeth	mm	13 – 15
Angle of the teeth	degrees	oct-15
Teeth profile	-	Straight or at an angle of 10°
Hardness of the meta	-	H20

Please pay attention to the following issues when sawing with a circular saw:

- Ensure the saw plate is sharp.
- Point the visible side of the board upwards.
- Set the saw plate to the correct height.
- Press down the board appropriately next to the saw plate.
- If possible, use a saw with “scoring”.

#### Sawing with a jigsaw:

Use a saw blade made of hardened steel with a medium tooth size with regard to a jigsaw with an upwards sawing direction. Ensure that the visible side of the board is pointing downwards. Ensure that the recesses in the board are not cut out sharply. Drill or mill these corners to prevent splitting.

#### Drilling holes:

We recommend following the instructions below when drilling holes.

- Ensure you have a flat and solid substrate to prevent crumbling around the drilled hole.
- Use an HSS (high speed steel) drill with a 60 – 80° widia cutting point.
- The inside edges of the drilled hole must be rounded off with a radius of at least 8 mm to prevent splitting.

#### Milling:

Ki-Kern boards can be processed using a manual surface milling cutter or a fixed bench milling machine. Use a hard metal milling cutter. This will prevent the edges from damaging and, in addition, it may visually be very beautiful.

In the unlikely event that you should have to remove the protective film anyway when sawing, always indicate on the visible side of the board that this is the front. You can thus prevent the transposition of the UV-layer during installation. This will ensure that in the future there will not be undesired aesthetic differences or excessive discoloration.

## 4.0 Processing

### 4.1 General

#### 4.1.1 Transport

Use stable and flat pallets that have at least the dimensions of the boards when transporting Ki-Kern boards. Ensure that the boards do not slide over each other and, thus, cause damage when loading and unloading boards. The best option is to lift the boards one by one.

The protective film must be removed immediately after installation.

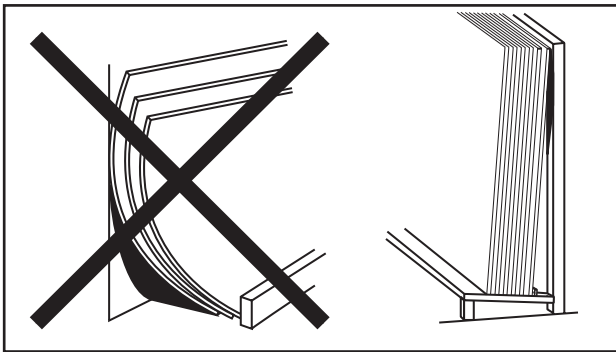

figure 1

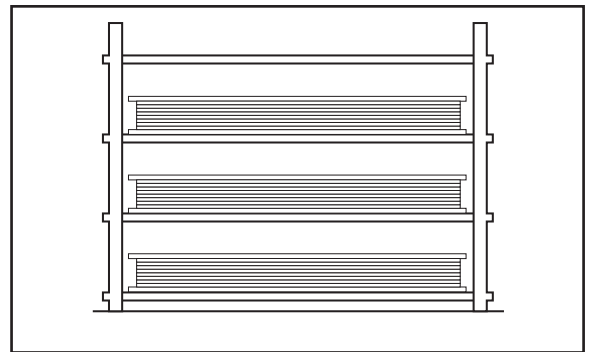

figure 2

#### 4.1.2 Storage

Ki-Kern panels must be stored in the following way:

- Store them in a closed dry room under normal climate conditions.
- Store them at an environmental temperature of:  $23 \pm 5^\circ \text{C}$
- The relative humidity should be:  $65 \pm 10\%$
- Store horizontally; if horizontal storage is not possible, the boards can be positioned at an angle of  $60^\circ$  or  $70^\circ$  where the total surface is supported. (Figures 1&2).
- Provide support for the whole surface.
- Cover the top board with tarpaulin, a cover plate or a covering layer.
- Do not expose to sunlight or rain when being stored.
- The weight of the stacked pallets may not be more than 2,000 kg.
- Always ensure that moisture cannot penetrate between the protective film and the Ki-Kern board.

### 4.2 Design provisions

#### 4.2.1 Design

The following issues must be paid attention to if Ki-Kern panels are to be used as a wall cladding system.

- The panels must be installed as a self-supporting, freely suspended wall cladding system.
- The wall cladding system does not have a stabilising effect on the whole wall structure.
- Heavy objects that are mounted on the panels require additional structural provisions, in particular, with regard to the load-bearing structure.
- The strength and stiffness of the panels in combination with the load-bearing structure should be sufficient when the correct dimensioning and application are used in accordance with the Ki-Kern processing instructions to resist any occurring loads such as wind, dead weight and/or temperature or moisture loading.
- Panels that have been provided with the special UV-coating are protected by a protective film on the top layer to ensure they cannot be damaged when shipped, handled or tooled. This protective film is basically vapour-proof. This protective film must be immediately removed after installation to ensure that high one-sided tensions cannot occur in the board after installation.
- The maximum impact loads of the panel and the structure behind that can be absorbed can be determined through a sandbag pendulum test.

### 4.2.2 Joints and panel joints

Panel dimensions may be influenced as a result in changes in temperature and humidity. Panel, installation and building tolerances also play a role when installing the Ki-Kern panels. This means that the guidelines below are important:

- A minimum width of joints of 10 mm must be maintained both horizontally and vertically;
- The joints must be implemented in such a way that water can be easily discharged so that damage due to moisture remaining cannot occur;
- Vertical joints must continue and may not end in a horizontal joint;
- Provisions must be made when there are joints that are larger than 10 mm (gauze, roosters, etc.) to ensure that insects and vermin are kept out (this is required in the Netherlands in accordance with the Dutch Building Decree). (See Fig. 3).

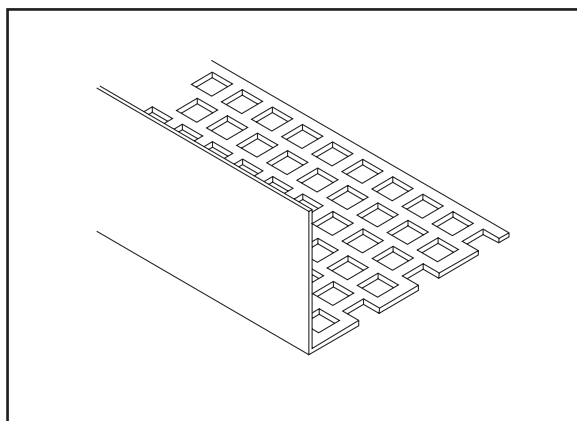

figure 3

Joints can be either open or closed ones.

The Ki-Kern wall cladding system offers the following options:

- Open joint (horizontally and vertically);
- Halved joint (horizontally and vertically);
- Closed joint with a sealing profile (Ki-Kern horizontal profile).

The sealing profiles may be made from aluminium or PVC.

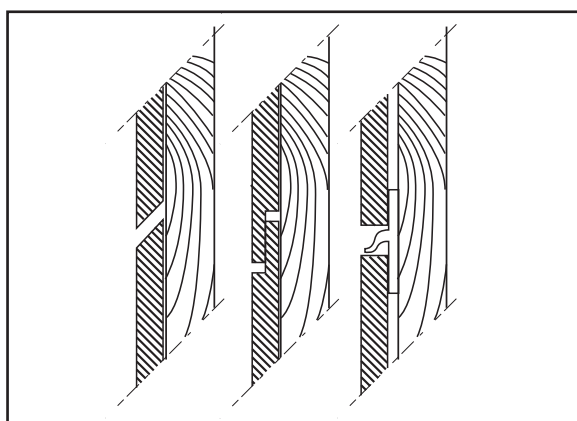

figure 4

### 4.2.3 Open joints

Criteria must be met with regard to the quality of the insulation material when using a vertically and/or horizontally open joint system. If required, a moisture-pervious film may be directly applied behind the board as an additional water barrier. If a wooden load-bearing structure is being used, it must be of a preserved quality. (See Fig. 5 drawings 2 and 3)

#### 4.2.4 Closed joints

A closed joint system can be implemented by using various sealing profiles such as the Ki-Kern vertical and horizontal synthetic material profiles. If, for example, metal or hard synthetic material profiles are used, they may not hinder the way in which the Ki-Kern panels work. The boards can be provided with a tongue and groove joint and/or a halved joint from a board thickness of 8 mm. It is important that the panels are not hindered in their operation when applying such profiles. (See Fig. 5 drawings 1, 4 and 5.) The use of synthetic material or aluminium H profiles and/or elastic putty as a joint sealer are not recommended. This could impede the operation of the Ki-Kern panels while panels will absorb dirt faster when sealed joints are used on the edges. (See Fig. 6).

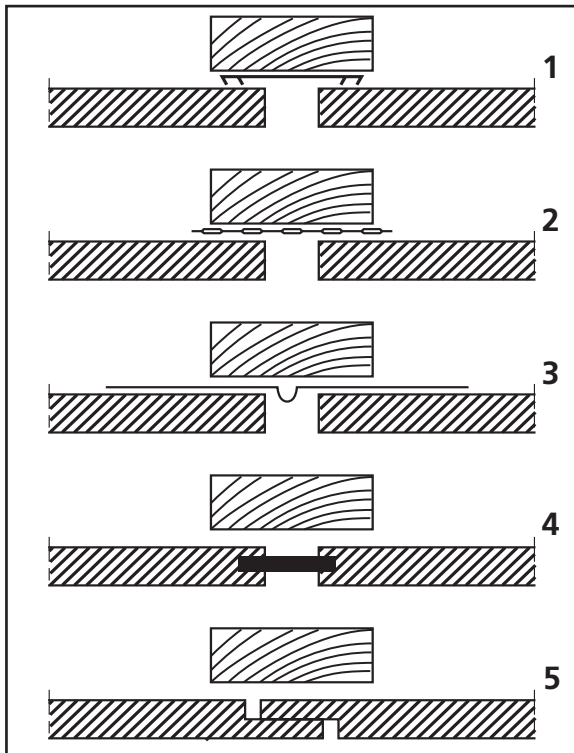

figure 5

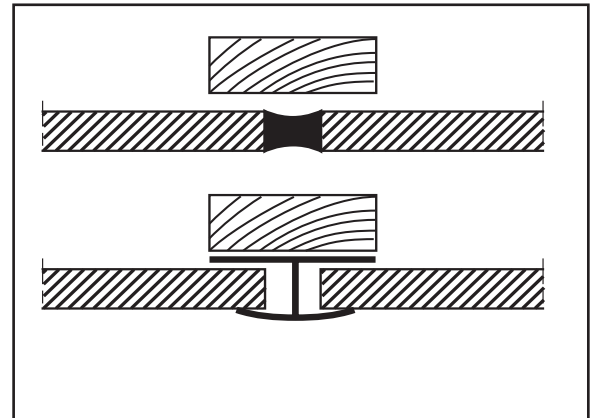

figure 6

### 4.3 INSTALLATION METHODS

The criteria related to the vertical trussing and battening are given attention in this section. The principles for the installation methods are also included in this section (visible and blind mounting).

#### 4.3.1 Vertical trussing and battening

The vertical trussing and/or battening that are anchored on to the structure behind must be made from, for example, wood, aluminium or steel. It must have sufficient strength and must continue to be durable. The load-bearing structure consists of continuous vertical members where the open ventilation space in-between the panels and rear wall must at least be 20 mm. We recommend having a minimum of 28 mm ventilation space with regard to dark colours and décors.

It is paramount that the load-bearing structure has been correctly aligned to ensure flat battens.

#### Building structure behind

A check must first be performed with regard to strength, stiffness, stability and flatness of the building structure behind before installing the panels (see section 2.5).

The material used the most for the vertical trussing and/or battening is wood. The wood must be healthy and must have been preserved. The centre-to-centre distance of the members must be implemented in accordance with the table below. The members must have a minimum width of 44 mm and a thickness of 34 mm (because of the attachment material used). At the places where 2 panels are mounted, the width of the members must at least be 75 mm.

The members can be installed:

- Where there is a joint;
- At a panel end;
- At an intermediate member.

Centre-to-centre distances of the battening:

Horizontally		400 - 600 mm
Vertical	panel thickness of 6 mm:	200 - 600 mm
	panel thickness of 8 en 10 mm:	200 - 700 mm

### Wood and laminated wood

Structures must have been made of right-angled wood and not multiplex that at least meets the conditions below:

1. Wood can be classified in a strength class in accordance with 9.1.2 of NEN 6760;
2. The moisture content of the wood must be between 16 and 20%;
3. The wood does not have any active damage and has not been damaged by larvae, insects and/or mould;
4. The wooden parts can be classified in one of the durability classes ranging from I to V in accordance with Annex G of NEN 6760;
5. A quality class C applies to sawn softwood in accordance with BRL 2301.

### Load-bearing structure connection means

Wood connection means must be applied to produce the load-bearing structure that at least meet the criteria with regard to the allowable size deviations and the basic criteria for quality class I in accordance with 5.2 and 5.3, respectively, of NEN 6762.

### 4.3.2 Structural design

Values are specified in NEN 6702 for the thrust as a result of wind load for the different wind regions in the Netherlands. You can obtain a calculation value for the static wind load from these values that should be used when selecting the dimensions of the Ki-Kern panels or for the calculation of the quantity of glue required per m<sup>2</sup> in the case of glued systems.

The following formula is the principle behind this:  $P_d = \gamma_f \times C_t \times P_w$  (kN/m<sup>2</sup>) where:

$P_d$  = calculation value for the static load;

$\gamma_f$  = magnification factor;

- 1.2 for panels when calculating the maximum allowed load for the attachment points;

- 0.7 for panels when the maximum allowed sag is being calculated;

$C_t$  = combination of the acting wind factors (NEN 6702);

$P_w$  = thrust as a result of wind load.

The following criteria also apply:

- The panels must be able to absorb the full wind load and transfer it to the building structure behind (via the structure behind and the anchors);
- The sag of the panels must be smaller or equal to  $1/200 \times$  the span and/or the attachment distance;
- The distance of the attachment materials up to the edges of the panel must at least be 20 mm and must not be more than  $10 \times$  the panel thickness when systems are attached mechanically.
- That which has been included in section 4.4.4 and in the KOMO certificate with a product certificate, 20793, applies to glued systems.

The maximum allowed wind loads are specified in tables 1 and 2 in accordance with NEN 6702 with regard to mechanically attached systems with regard to the forces that act as a result of wind suction in relation to the distance of the attachment points (visible and blind attachment.)

Table 1 – Maximum allowed force N for each attachment point with regard to distances (centre-to-centre) between the struts of 400, 600 and 700 mm (visible attachment)

Thickness of the panels	Distance (H) between the struts (mm)	Position of the attachment points on the panel		
		Centre	Edge 1)	
6 mm	400	370	245	215
	600	340	170	115
8 mm	400	370	370	370
	600	370	370	220
	700	370	370	
10	400	370	370	370
	600	370	370	220
	700	370	340	

1) The distances to the edges of the panels must at least be 20 mm and must not be more than 100 mm.

Table 2 – Maximum allowed static load Pd with regard to the concealed attachment.

Position of the attachment points V x H	Vertical distance (V) between the attachment points (mm)	Horizontal distance (H) between the attachment points (mm)				
		300	400	500	600	700
2 x 2	400	≥ 3000	≥ 3000	2850	2450	1700
	500	≥ 3000	2900	2450	2100	1700
	600	≥ 3000	2500	2100	1800	1700
2 x n <sup>1)</sup>	400	2400	1800	1400	1200	1000
	500	2000	1500	1200	1000	850
	600	1750	1300	1050	850	750
n x 2 <sup>1)</sup>	400	2400	1900	1600	1400	1200
	500	1900	1550	1300	1100	950
	600	1600	1300	1050	900	800
n x n <sup>1)</sup>	400	1350	1000	800	700	600
	500	1050	800	650	550	450
	600	900	700	550	450	400

1) = n > 2

### Sag

A minimum load of 600 N/mm<sup>2</sup> should be used in the calculations (for both wind suction and pressure) to prevent failure of the wall cladding system as a result of a sag that is too strong perpendicularly on to the plane.

### 4.3.3 Ventilation cavity

This ventilation cavity is used for the following:

- To prevent damage to the wall as a result of condensation in the cavity and/or to prevent rain penetration.
- To limit cold bridges because the load-bearing structure is insulated on the outside.
- To limit the expansion and shrinkage of the main structure due to (slight) temperature changes.

Openings must be available at the bottom and at the top of the wall cladding to ensure good ventilation. This also applies to the connections at the door and window openings.

The size of the ventilation opening is determined by 2 factors:

- By the height of the wall cladding;
- By the local conditions.

Per strekkende meter gevelbreedte dient tenminste aanwezig te zijn: The following must at least be available for each running metre of wall width:

- 20 cm<sup>2</sup> per m<sup>1</sup>; for a wall cladding height up to 1 metre<sup>1</sup>
- 50 cm<sup>2</sup> per m<sup>1</sup>; for a wall cladding height greater than 1 metre<sup>1</sup>

The ventilation openings may be reduced to 5 mm at certain places.

Ventilation openings that are larger than 10 mm must have provisions (wire gauze, grills, etc.) to keep out insects and vermin (required in accordance with the Dutch Building Decree in the Netherlands).

(See Fig. 3).

An opening must be available at the top (for example, at a roof trim) that measures at least 5 mm so that the continuous ventilation is not impeded.

At least 200 mm must be kept free from ground level to ensure the ventilation is not impeded and/or to stop dirt from splashing up. (See Fig. 9).

The battening should be applied in such a way with regard to horizontal applications (for example, eaves or ceilings), that the ventilation will take place over the shortest side. (See Fig. 7).

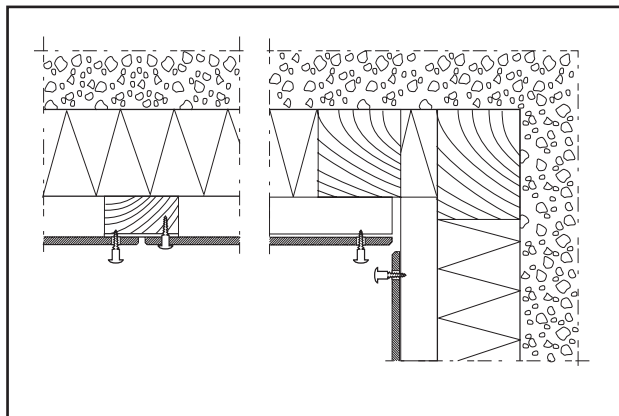

figure 7

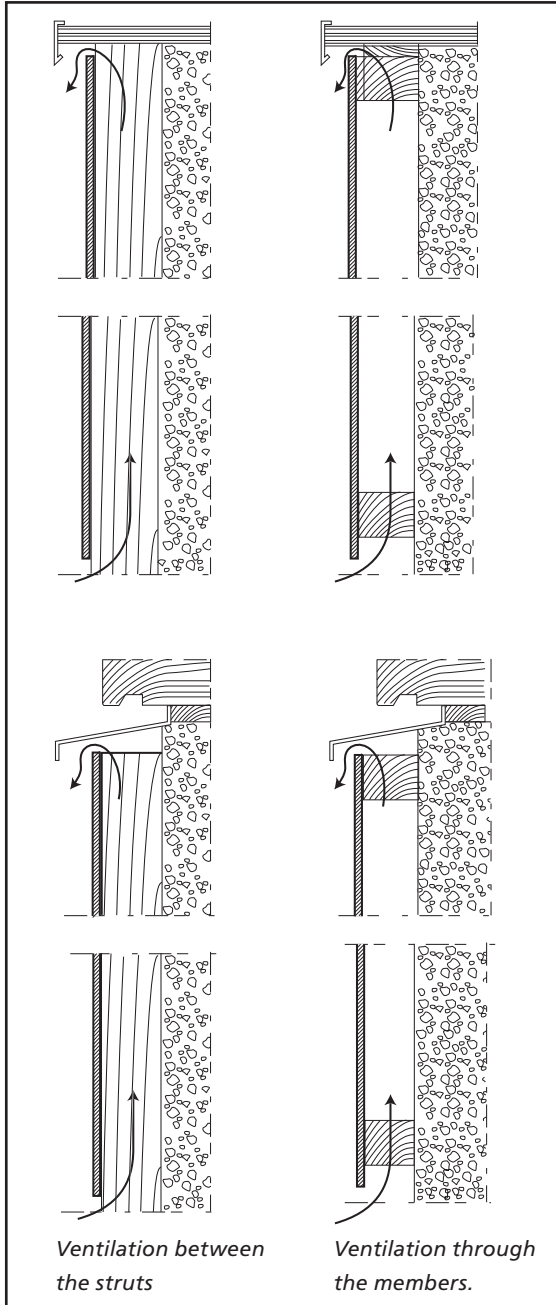

figure 8

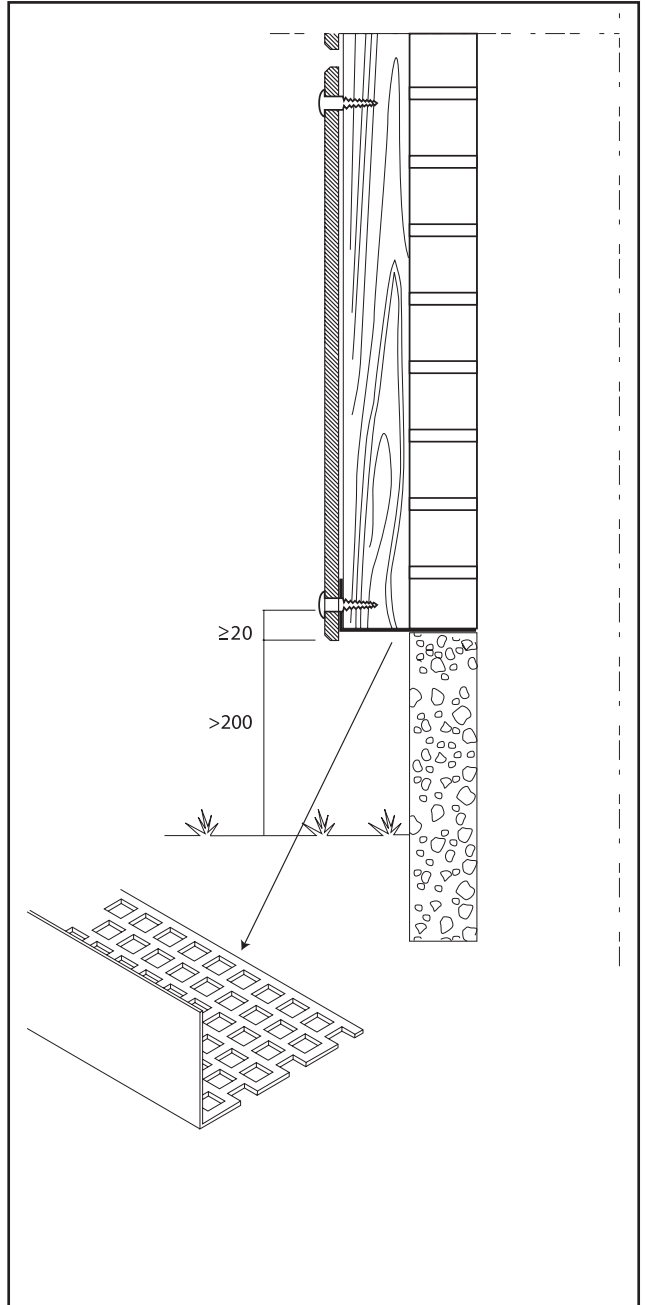

figure 9

#### 4.4 Attachment

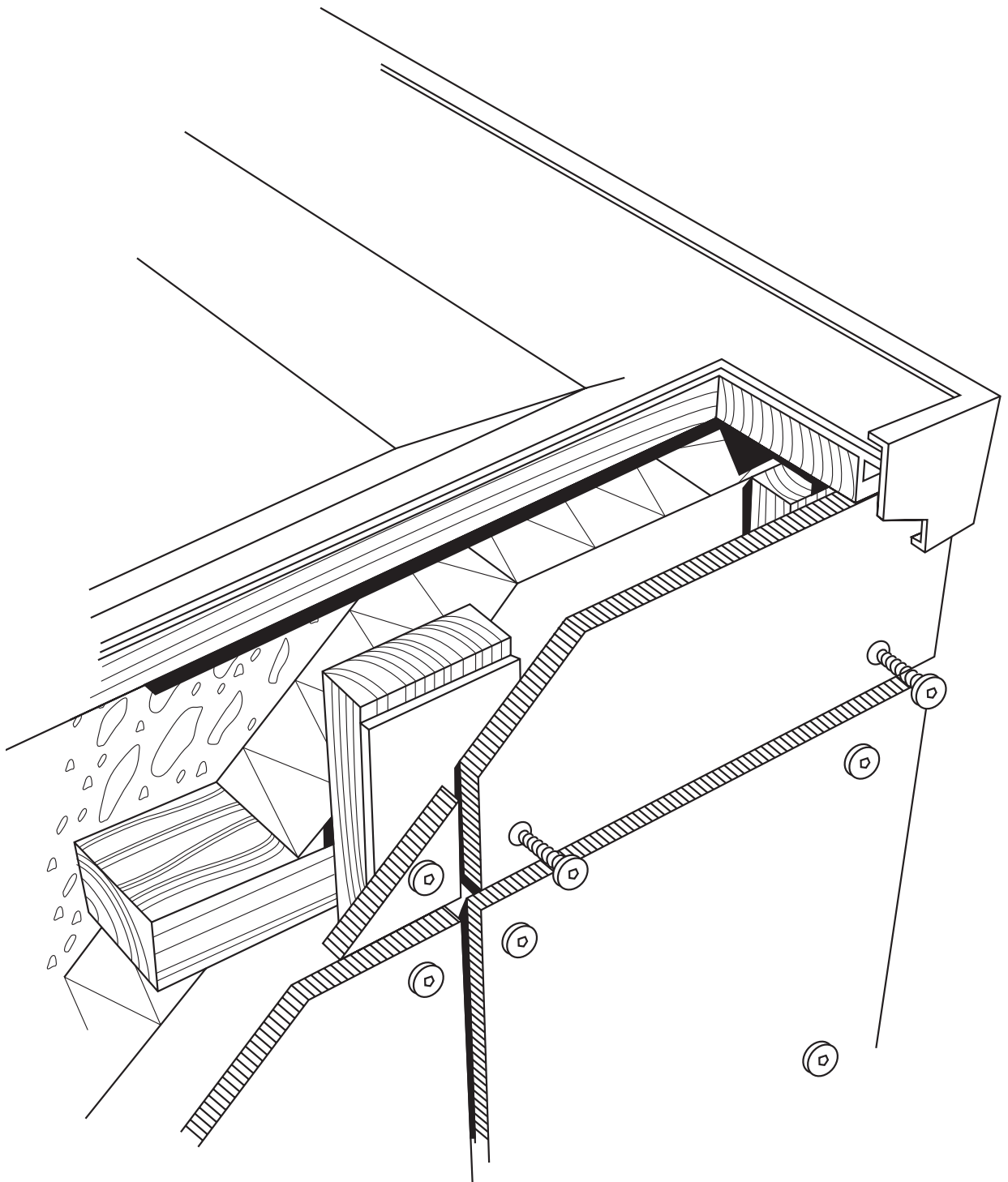

figure 10

#### 4.4.1 Visible attachment

Ki-Kern panels can be screwed on to a wooden structure behind as from 6 mm. The structure behind must consist of vertical trussing and/or battening as described in section 4.3.1. Use All-Tight rapid installation coloured tap torx screws for the attachment (also see section 4.4.2, Attachment materials). Replace the bit every hundred screws to prevent damage to the coloured tap screw.

#### Basic principle

Joints: at least 10 mm

Panel thickness: from 6 mm

#### Edge and attachment distances

a = horizontal attachment distance (see Fig. 12).

b = edge distance:

- At least: 20 mm
- At most: 10 x panel thickness

c = vertical attachment distance (see Fig. 12).

#### Maximum attachment distances (in mm)\*

Panel thickness (in mm)	6	8	10
2 attachments in one direction	400	550	700
3 or more attachments in one direction	500	700	850

\* This values are indicative for the maximum allowed attachment distances for wall components and wall cladding on buildings with a maximum height of 12 m. If the Ki-Kern panels are being installed horizontally (for example, eaves , etc.), the maximum attachment distances must be multiplied by  $\frac{3}{4}$ . Further calculations must be carried out in accordance with the current NEN 6700 and NEN 6702 standards. For more information also see section 4.3.2.

#### Attachment detail

All-Tight rapid installation coloured tap torx screws for Ki-Kern panels from 6 to 10 mm.

Diameter of the holes for the attachment points:

- 5 mm for All-Tight rapid installation torx screws on fixation points.
- 1.5 x 5 mm for All-Tight rapid installation coloured tap torx screws on dilatation points (see Fig. 11).
- Shank diameter +3 mm for other screws

Wooden vertical trussing and battening at least:

- 34 x 75 mm for joints between two panels;
- 34 x 45 mm for intermediate and end struts/members.

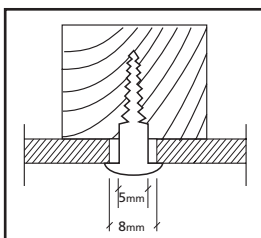

figure 11

Tighten screws centrally and not too tightly to ensure the operation of the panel is not impeded. The distance of the attachment materials up to the edges of the panels must amount to at least 20 mm and at most 10 x panel thickness in both cases. It is fixed in the centre of the panel by positioning an All-Tight screw in the drilled hole with a diameter of 5 mm. The All-Tight screws are positioned in a drilled hole with a diameter of 8 mm at the other attachment points so that the panel can expand and shrink in all directions as a result of temperature and humidity changes.

#### 4.4.2 Attachment detail

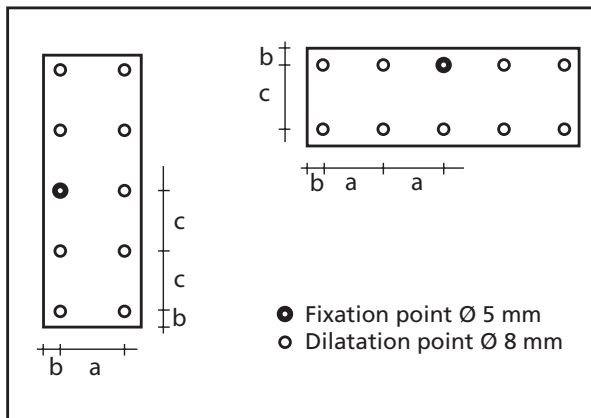

figure 12

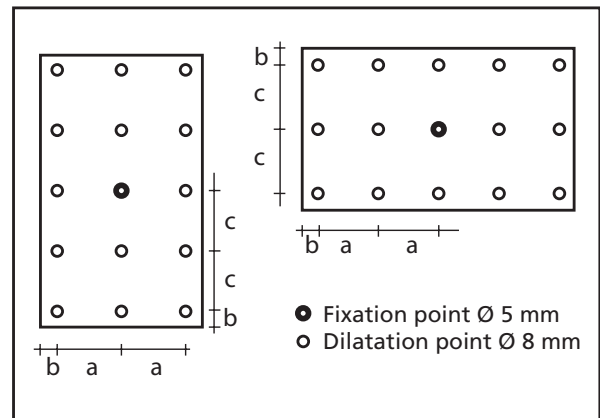

figure 13

#### Visible attachment

##### Wooden vertical trussing and/or battening

All-Tight rapid installation screw (4.8 x 38) for panel thicknesses of 6, 8 and 10 mm.

- Material: A2 - 18/8 stainless steel
- Diameter: 4.8 mm
- Length: 38 mm
- Head diameter: 12 mm
- Form: Torx T 20 W
- Hole diameter: 8 mm

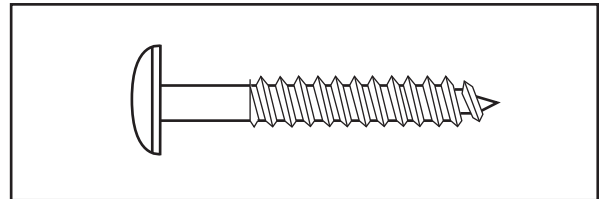

figure 14

All-Tight rapid installation screw (4.8 x 32) for panel thicknesses of 6 and 8 mm.

- Material: A2 - 18/8 stainless steel
- Diameter: 4.8 mm
- Length: 32 mm
- Head diameter: 12 mm
- Form: Torx T20 W
- Hole diameter: 8 mm

##### Steel vertical trussing and/or battening

All-Tight rapid installation screw (4.8 x 25) for panel thicknesses of 6, 8 and 10 mm.

- Material: A2 - 18/8 stainless steel
- Diameter: 4.8 mm
- Length: 25 mm
- Head diameter: 12 mm
- Form: Torx T20 W
- Hole diameter: 8 mm

Aluminium or stainless steel blind rivet (5 x 21) for a panel thickness of 6 mm.

- Material: stainless steel or aluminium
- Diameter: 5 mm
- Length: 21 mm (there must be a space of 0.2 mm between the cap and the panel surface)
- Head diameter: 14 mm
- Diameter of the holes: 10 mm

#### 4.4.3 Blind attachment

Vertical struts of wood, aluminium or steel are anchored on the structure behind with regard to the blind attachment of the wall cladding system on which horizontal aluminium profiles are attached. The Ki-Kern panels are attached to this by using anchors or cotter bolts.

##### Blind attachment

M6 anchor for a panel thickness of 10 mm.

- Material: screw: stainless steel  
anchor: messing
- Diameter: anchor: M6
- Length: anchor: 7.5 mm
- Diameter of the holes: 8 mm
- Depth of hole: 7.5 mm (special drill with depth stop)

Cotter bolt for panel thicknesses of 6, 8 and 10 mm.

- Material: A4 stainless steel
- Diameter: M6
- Diameter of the holes: 7 mm/9 mm (special drill with depth stop)
- Depth of hole: 4 mm for 6 mm panels  
5.5 mm for 8 mm panels  
7 mm for 10 mm panels

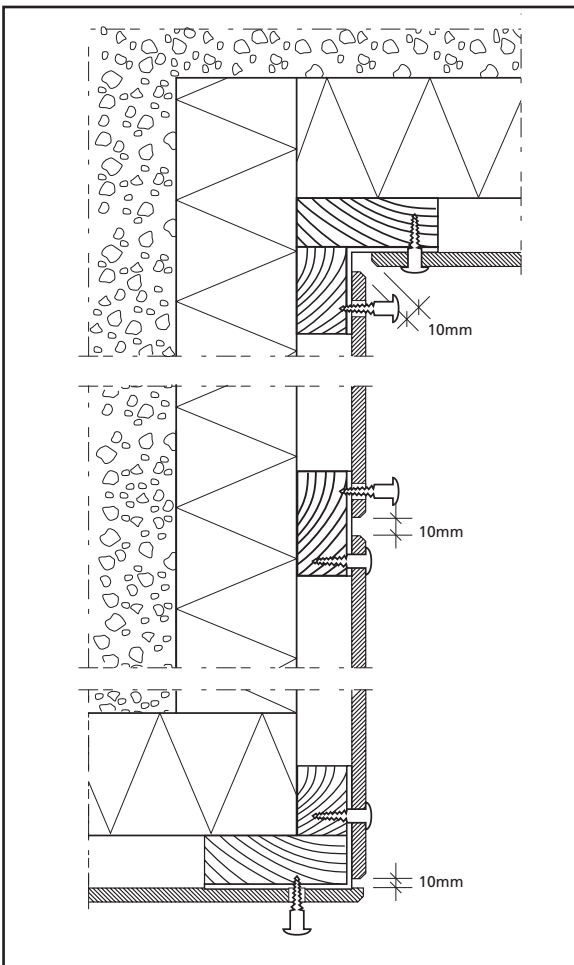

figure 15

Blind attachment

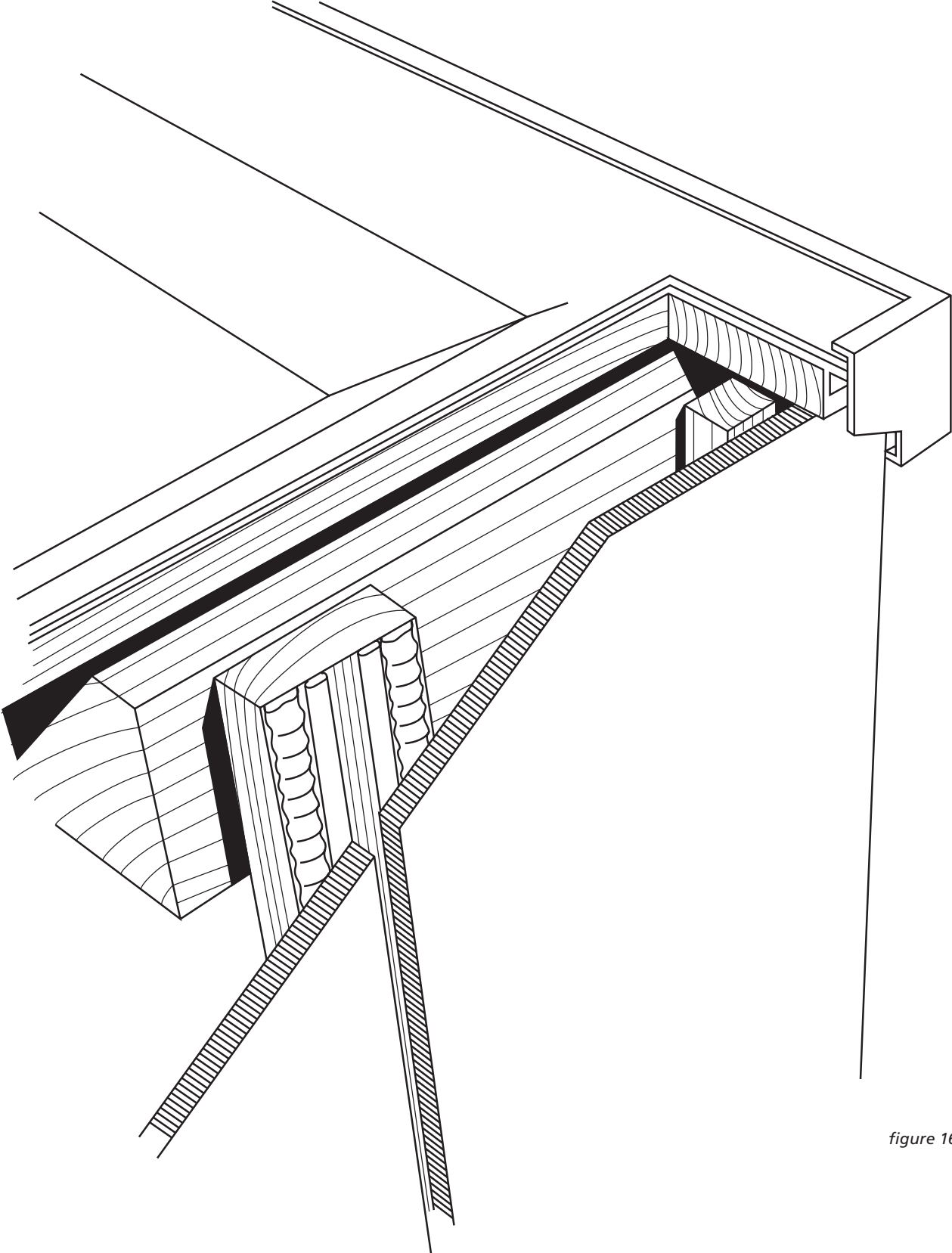

figure 16

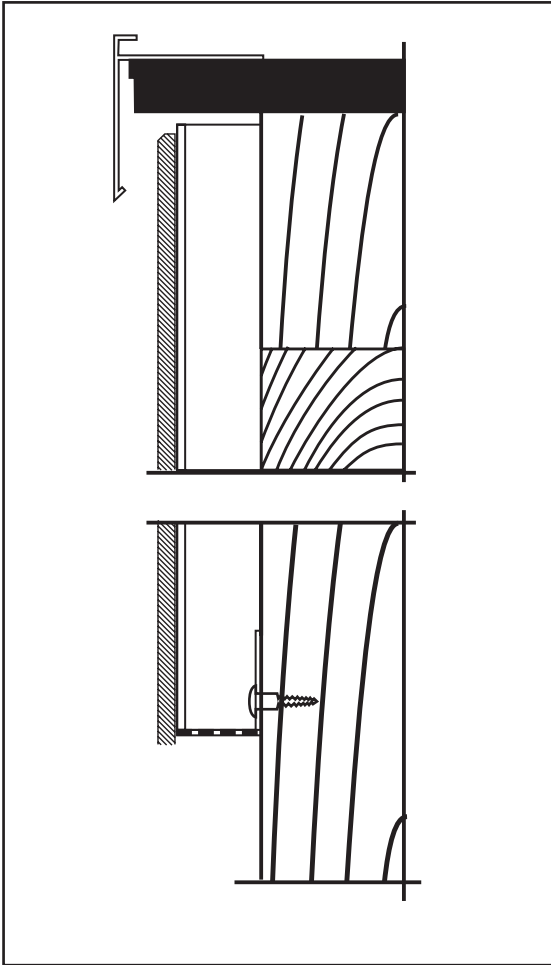

figure 17

#### 4.4.4 Gluing

Gluing Ki-Kern boards is very precise work. A perfect result will depend on a number of factors. Therefore, exactly follow the instructions below. We recommend using a professional application company with regard to applications involving the Ki-Kern Glue System in projects and/or in areas where the Ki-Kern Glue System will be applied heights greater than 10 metres.

##### Checklist

##### Check materials (make a note of this information):

- Shelf life and storage conditions for the glue.
- Storage and condition of the wall panels.

##### Check the climate (make a note of this information):

- Expected weather conditions.
- Determine the temperature (only proceed if between + 5 and + 40° C), the relative humidity and the dew point.

##### Check the structure behind:

- Sound construction (of preserved wood).
- Presence of ventilation.
- Position of the battening.
- Flatness of the battening.
- Wood moisture content of the battening (make a note of this value)

### Treatment of the vertical trussing and battening

The vertical trussing and/or battening can be protected against moisture penetration and, at the same time, perfect adhesion can be created with the Ki-Kern Tape and Ki-Kern Glue Putty by using Ki-Kern Primer. Ki-Kern Primer must be shaken well before use. Ki-Kern Primer should be applied by using a roller (10 cm) and a paint tray. The primer should be applied by exerting a slight pressure in a regular manner. Ki-Kern Primer must be applied twice with regard to porous substrates. The drying time for Ki-Kern Primer amounts to approximately 30 minutes. Do not prepare more than will be glued on that day.

### Cleaning

The Ki-Kern Wall cladding to be glued must first be cleaned on the vertical trussing and/or battening using Ki-Kern Cleaner to ensure the best possible adhesion. This should be done by using a fluff-free cloth soaked in Ki-Kern Cleaner and by, subsequently, rubbing hard in one direction (to ensure that dirt cannot be spread). After cleaning, both the Ki-Kern wall board and the vertical trussing and/or battening must be dry before you can apply the Ki-Kern Primer, Ki-Kern Tape or Ki-Kern Glue Putty. The drying time for the Ki-Kern Cleaner amounts to approximately ca 90 seconds.

### Applying the tape

Ki-Kern Tape has 2 goals;

- 1 Providing the first initial adhesion of the Ki-Kern wall cladding during the drying of the Ki-Kern Glue Putty.
- 2 Realise a minimum and necessary height of the glue groove. This is realised due to the Ki-Kern Tape.

The Ki-Kern Tape must be applied to a clean, dry, grease-free and primed substrate. To ensure that the glue putty does not flow into the joint, the Tape must be applied to the board edge side so that the glue in the glue groove does not flow into the joint. The distance of the Tape with regard to the Putty is 10-15 mm. The intermediate members must also be provided with Ki-Kern Tape and Ki-Kern Glue Putty.

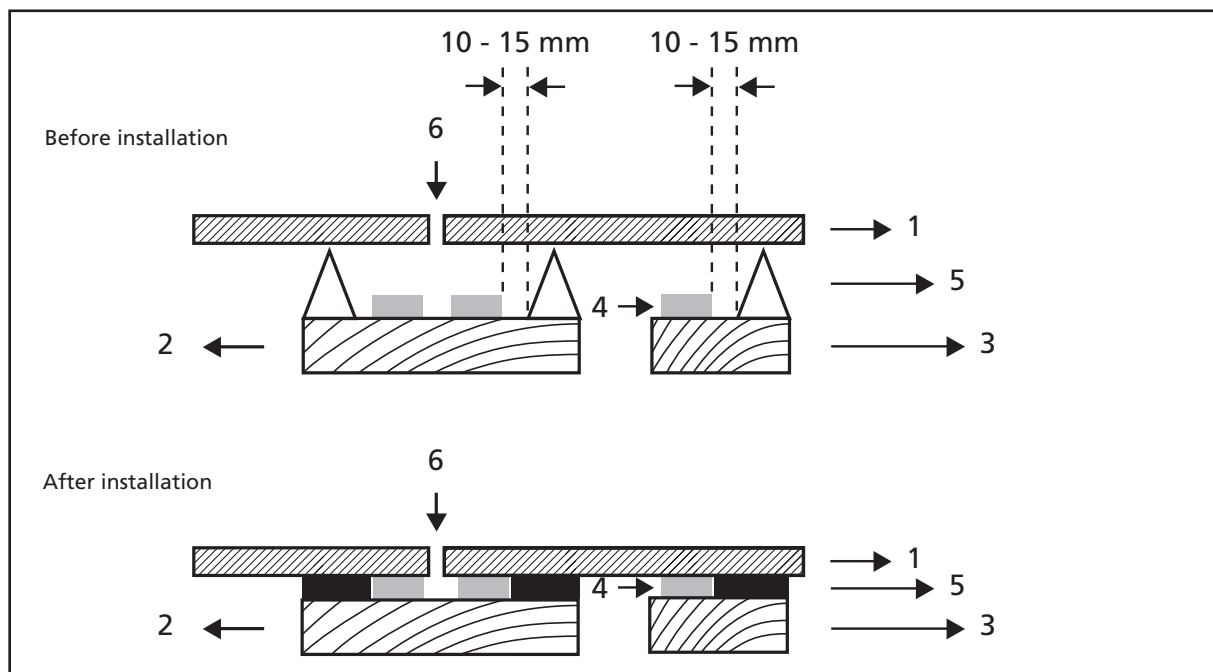

figure 18

- 1 Ki-Kern solid synthetic material board
- 2 Vertical trussing and/or Battening (connecting member)
- 3 Vertical trussing and/or Battening (intermediate member)
- 4 Ki-Kern Tape
- 5 Ki-Kern Glue Putty
- 6 Minimum width of joint 10 mm in accordance with the instructions

After the Ki-Kern Glue Putty has been applied, the protective film must be removed from the Ki-Kern Tape before positioning the Ki-Kern boards.

### **Applying the glue putty**

The required end result will only be attained if the quality of the material is good and if installation is carried out in the correct manner. Always use the supplied triangular nozzle for applying the Ki-Kern Glue Putty; this will ensure that the correct glue ratio is applied. The Ki-Kern Glue Putty must be applied without interruptions over the whole of the length of the vertical battening and on the intermediate members. The distance of the Tape with regard to the Putty is 10 – 15 mm. After applying the Ki-Kern Tape and the Ki-Kern Glue Putty, the film must be removed from the tape to install the wall cladding.

### **Installing the Ki-Kern wall cladding**

Installing the Ki-Kern wall cladding is a very exact operation. There will be immediate adherence between the boards and the Ki-Kern Tape when they come into contact that cannot be corrected.

Therefore, follow the following instructions:

- Determine the correct position;
- Position the board securely in the glue groove (use, if required, an adjustment block);
- Exert pressure solidly on the board so that it makes contact with the tape everywhere.





The time in-between applying the Ki-Kern Glue Putty and the Ki-Kern wall cladding must amount to no more than 10 minutes; take this into account when preparing to carry out the work.

### **Final check and finishing**

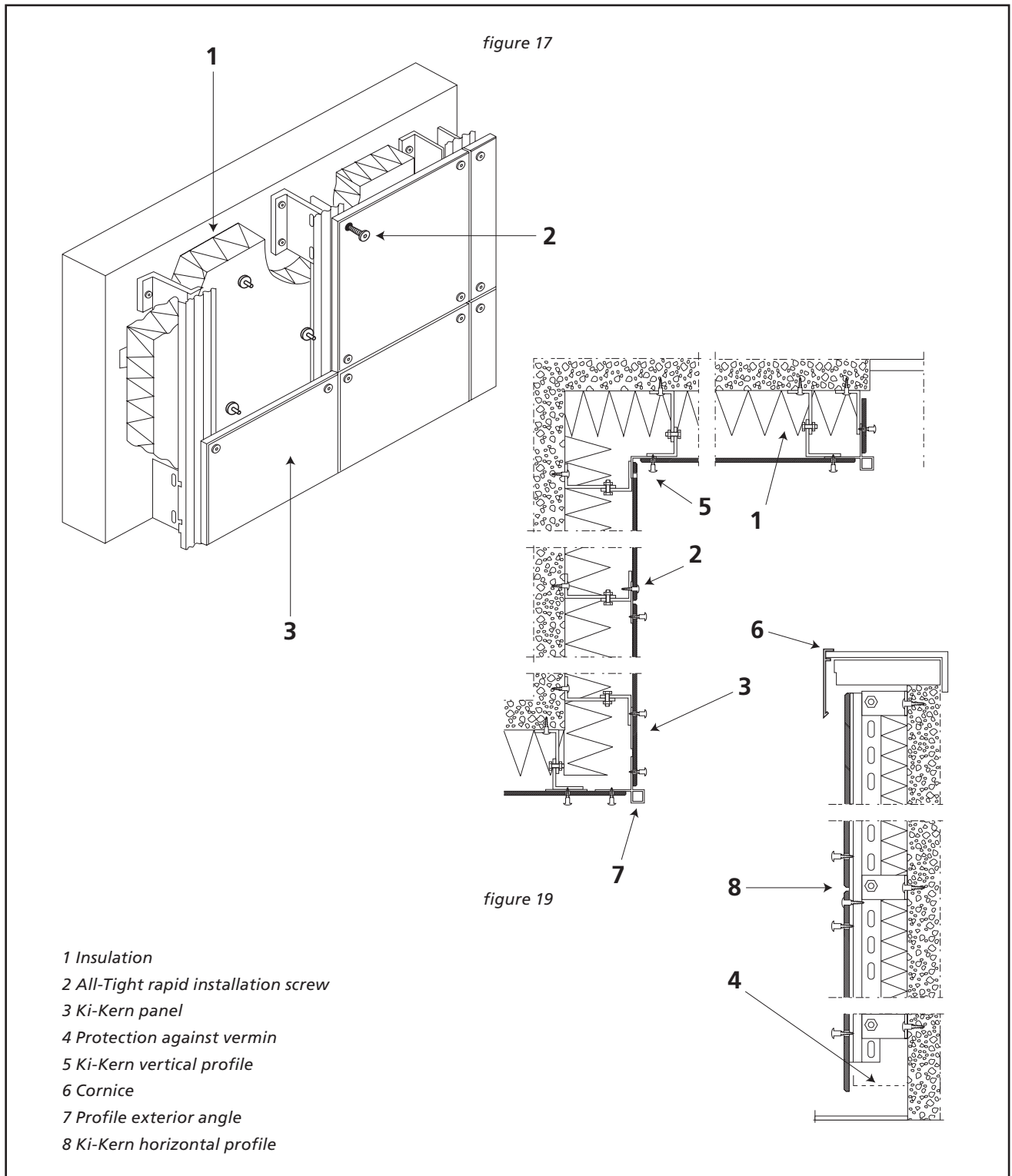
When the Ki-Kern wall cladding has been installed, we recommend to immediately removing any surplus putty and/or putty on the surface of the board. Use for this the Ki-Kern Cleaner.

## 5.0 Drawing sheets





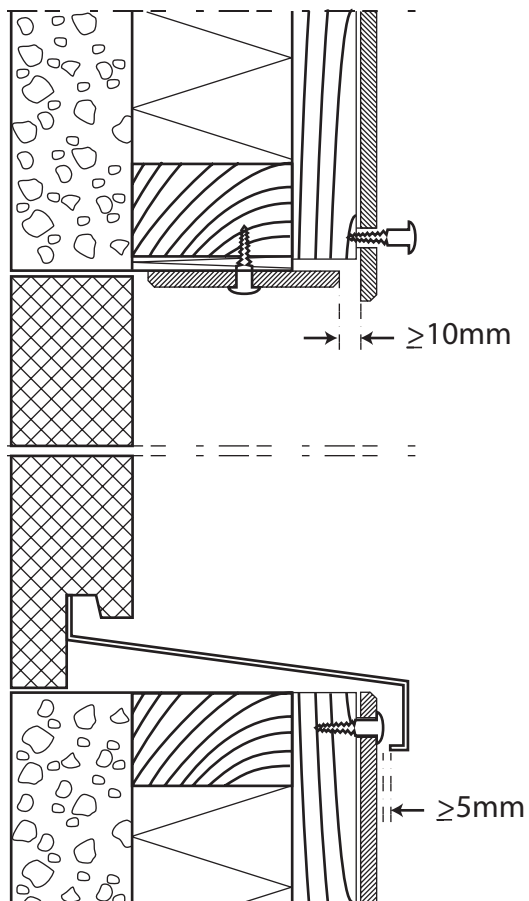

-  Ki-Kern panel
-  Load-bearing structure, horizontal girder
-  Building structure behind
-  Insulation material

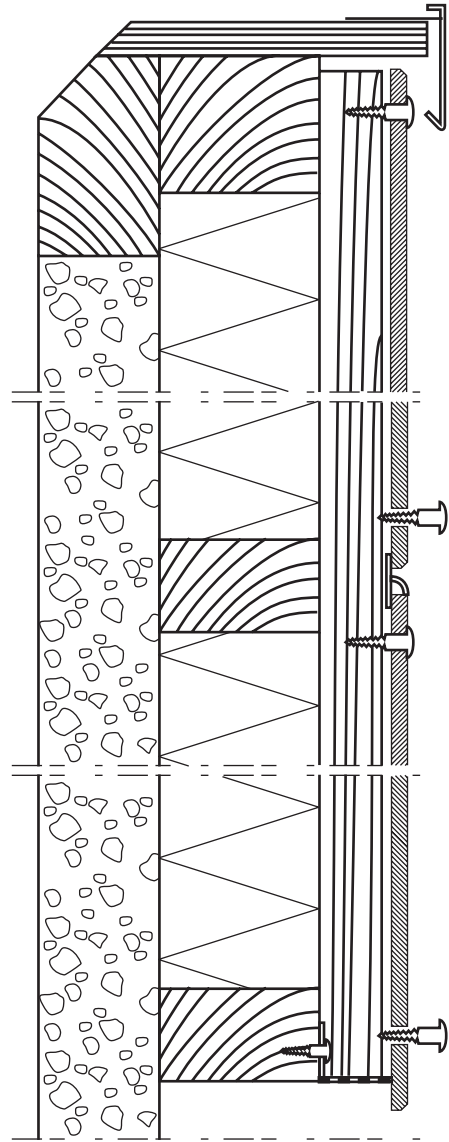

window detail figure 20



wall detail figure 21

-  Ki-Kern panel
-  Load-bearing structure, horizontal girder
-  Building structure behind
-  Insulation material

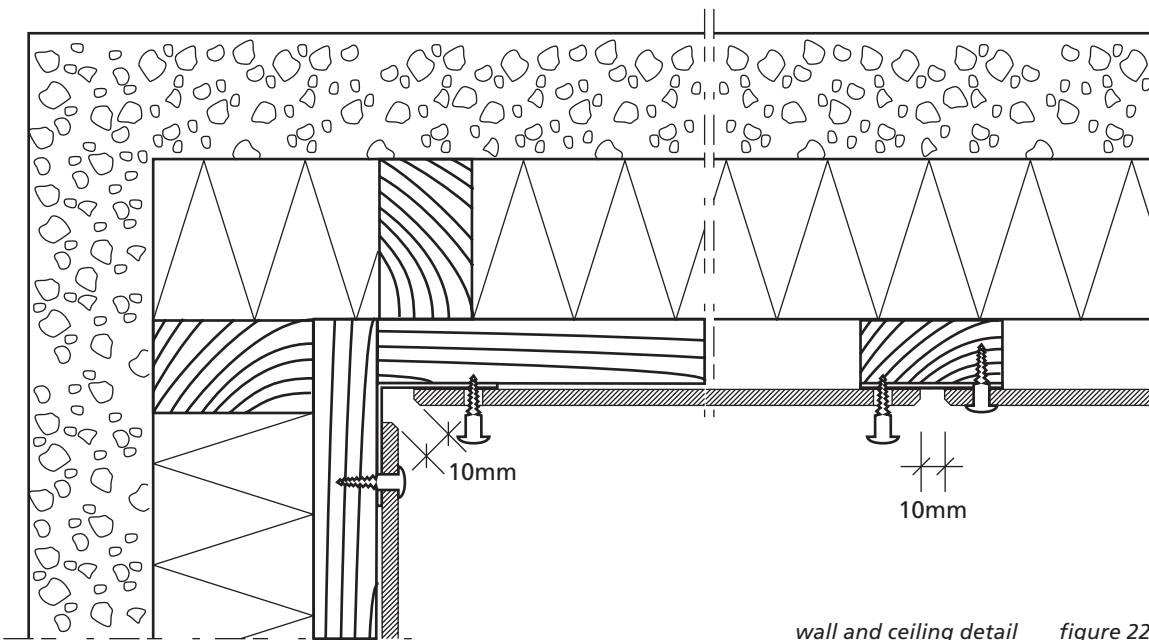

wall and ceiling detail figure 22

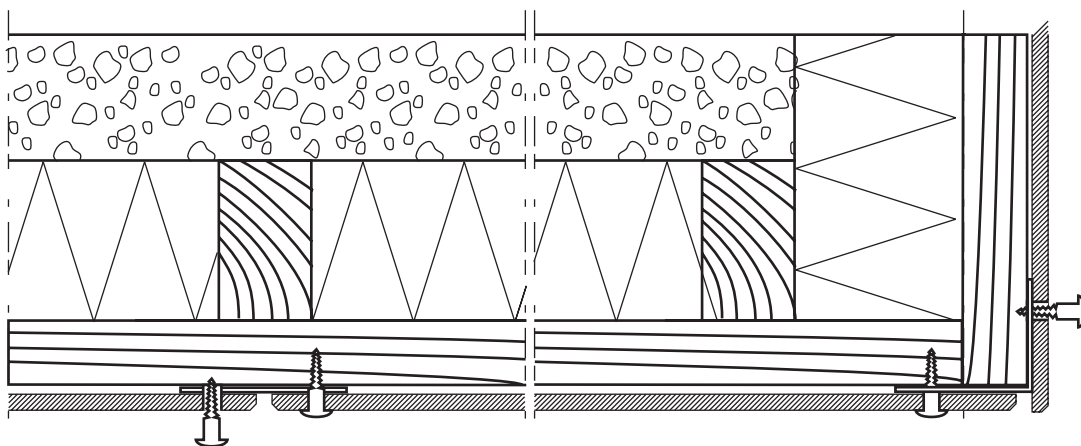

ceiling and roof gutter detail figure 23



## 6.0 Cleaning Ki-Kern

Spots created by	a normal cleaner Ajax/Andy/etc.	Methylated spirits/Glassex hydrocarbon:	Ki-Kern Cleaner
Fingerprints	X	X	
Grease/oil/sole markings	X		
Soot/nicotine	X		
Water-based paint/ ink	X		
Coffee/tea/juice	X		
Wax crayon/ball pen markings		X	
Felt-tip pen markings		X	X
Paint/adhesive <sup>1</sup>			X
Lime/ soap deposits <sup>2</sup>	X		
Rust spots	X		X

1) Paint can be removed by using a sodium hydroxide-based paint remover.

2) Lime deposits in, for example, bathrooms can be removed by using a 10% acetic acid solution. So-called descaling agents must be used with the utmost care. These liquids may contain corrosive chemicals.

**Always first try out the cleaning agent on a small piece that is not visible.**

Never use ethyl acetate, thinner or a similar product to remove spots. Avoid pressing with force to remove spots: this may lead to differences in shine. See for more products section 8.0, Resistance.

If you wish to apply an anti-graffiti system for removing graffiti, please contact:  
Chemtec Chemicals bv  
Telephone: 010 – 4120974

Mention that it involves Ki-Kern.

## 7.0 Resistance

<b>Name</b>	<b>Resistance Melamine</b>	<b>Acryl</b>
Acetone	+	-
Alcohols	+	-
Aldehyde group	+	-
Aluminium chloride	0	0
Amino acids > 10% 0	0	-
Ammonia solution (10%)	+	0
Ammonium sulphide 10%	0	-
Aniline	-	-
Ascorbic acid	+	-
Acetic acid, concentrated	+	-
Acetic acid 5%	+	0
Petrol/benzene	+	-
Dichromate sulphuric acid	-	-
Blood	+	+
Boric acid	-	-
Bromide solution	-	0
Butyl acetate	+	-
Calcium chloride	+	+
Concrete	+	+
Hydrochloric acid Hydrogen chloride	0	+
Citric acid < 20%	+	+
Dimethyl formamide	+	-
Grape juices	+	+
Ethyl acetate + -	+	-
Phenol 90% + -	+	-
Ferric chloride 0 +	0	0
Formalin + -	+	-
Phosphoric acid < 10% 0 0	0	0
Phosphoric acid > 10% - 0	-	0
Plaster	+	+
Glycerine	+	+
Glycol	+	+
Grapefruit juice	+	+
Hair-dye	0	-
Hexamine 30%	+	-

<b>Name</b>	<b>Resistance Melamine</b>	<b>Acryl</b>
Iron chloride 60%	0	0
Iron sulphate 30%	0	0
Ink	+	0
Iodine 0.1%	0	+
Potassium hydroxide	0	+
Potassium iodide 10%	0	-
Potassium permanganate solution	0	+
Lime solvent	-	-
Coffee	+	+
Copper sulphate	+	0
Mercury chromate 2%	0	+
Lactose	+	+
Varnish (acid-hardening)	+	+
White spirit	+	-
Lipstick	+	+
Magnesium chloride	+	+
Lactic acid (20%)	0	0
Methane acid	0	-
Methylene chloride	+	-
Methyl ethyl ketone	+	-
Sodium chloride (Hydrochloric)	+	0
Sodium hydroxide (soda)	0	0
Sodium nitrate	+	0
Sodium sulphate	+	+
Sodium sulphide	+	+
Sodium sulphite	+	0
Nicotine	+	+
Oil (mineral)	+	+
Oxalic acid	0	+
Paraffin	+	+
Beetroot juice	+	+
Salicyl acid	+	-
Nitrate < 40%	-	0
Shoe polish	+	+
Soda < 10%	+	-
Soda > 10%	0	-
Salad dressing	+	+
Sorbitol	+	-
Stamp-pad ink	+	+

Name	Bestandheid Melamine	Acryl
Turpentine	+	0
Tetrachloride carbon	+	-
Tea	+	+
Toluene	+	-
Ketchup	+	+
Trichloroacetic acid	+	-
Trichloroethylene	+	-
Triethylamine	+	-
Trisodium phosphate	+	+
Urine	+	+
Hydrogen fluoride < 10%	0	-
Hydrogen peroxide < 30%	0	0
Water/Water-based paint	+	+
Wax crayon	+	+
Wine vinegar	+	+
Tartar acid	+	0
Xylene	+	-
Silver nitrate	0	+
Zinc nitrate 10%	0	-
Hydrochloric acid < 10%	0	0
Hydrochloric acid < 32%	-	-
Sulphur	+	+
Sulphuric acid < 10%	0	-
Sulphuric acid > 10%	-	-

+ = No harmful effect

0 = Slight harmful effect (the surface will tarnish or discolour after a long corroding period.)

- = Not resistant against this (strong corrosion; discoloration: The chemical must be immediately removed.)



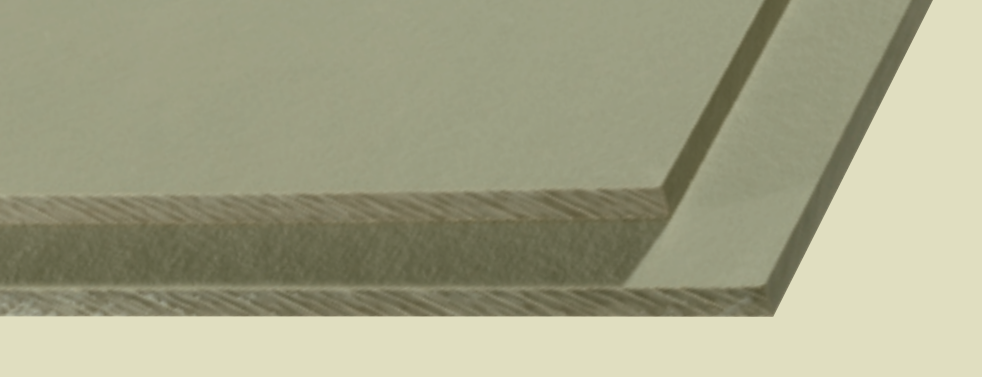

your Ki-Kern point of sale:

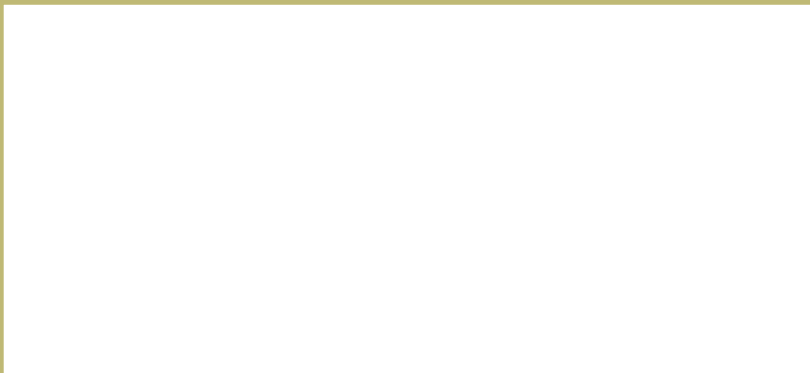

**Fetim Professional**

Tel.: +31 (0)20 580 5285

Email: [professional@fetim.nl](mailto:professional@fetim.nl)

[www.fetimprofessional.nl](http://www.fetimprofessional.nl)

[www.FrontsAndFronts.nl](http://www.FrontsAndFronts.nl)

